



**GENUINE MEGA**

SPECIALTY HAULAGE SOLUTIONS FOR CONSTRUCTION & MINING

**MAC/MAT** ➤

APPLICATIONS FOR CATERPILLAR®

# MEGA ARTICULATED TRUCK TANK



**EQUIPMENT** ➤

700 Osuna Rd. NE

**PARTS** ➤

Albuquerque, NM 87113

**SUPPORT** ➤

[www.megacorpinc.com](http://www.megacorpinc.com)



## THERE'S WORK TO BE DONE >

For over 45 years, Mega has been providing specialty haulage equipment for use in construction and mining operations. Our water haulage equipment, service bodies, bottom-dump trailers, equipment transports and other products are designed and manufactured to be reliable and durable machines. The knowledge and experience that comes from delivering over 6,000 machines is built into every product we make.

Our employees take pride in their workmanship and Mega has developed a reputation for manufacturing quality products that are built to last. Our sales and product support staff are known for providing solutions and demonstrating integrity throughout the ownership experience. Our product's value is reflected in our industry-leading brand recognition and resale value – Genuine Mega products have become the standard by which others are measured.

Mega products, parts and service can be found at OEM construction and mining equipment dealers around the world. Our sales and product support departments at Mega are available to help answer your questions. For more information, please contact us @ +1 505.345.2661 or toll free in the USA at 1.800.345.8889 or on the web at [www.megacorpinc.com](http://www.megacorpinc.com).

*There's work to be done – and, from all of us at Mega, we want to help you do it!*



*Jim Kunz*  
President Emeritus

## “ WE APPRECIATE YOU AND OUR PRODUCTS SHOW IT ”



Follow us on social media.

#GENUINEMEGA  
[www.megacorpinc.com](http://www.megacorpinc.com)



## < GENUINE MEGA VALUE

### > VALUE

- The water tank is essential to the operation of production tools
- Mega water tanks provide the highest levels of dependability and longevity
- The high quality Mega water tank provides a lower cost of ownership and more profit from production tools
- Mega water tanks compliment the premier brands of prime movers
- The superior longevity of Mega water tanks provides high resale value lowering the cost of ownership

### > DESIGN AND MATERIALS

- Mega works closely with OEM manufacturers to ensure our tanks properly fit, load, and interface with the prime mover resulting in a fully integrated machine
- Mega tanks meet or exceed applicable ISO/SAE/DOT recommended practices and requirements
- Materials and components used in the manufacture of Mega water tanks are chosen for high quality and durability rather than a low price point
- Mega water tanks feature the best interior baffling systems on the market resulting in a machine that is safe to operate with lower operating costs
- Key spray components are specifically engineered for severe duty heavy equipment service
- Mega spray system controls are designed to withstand the harsh corrosive environment of heavy construction and surface mining
- Mega water pumps are specifically designed for heavy equipment water tank service with features not found on standard off the shelf irrigation water pumps
- Mega spray heads (100% built in the USA) are the heaviest duty, most versatile, valve and spray fan nozzle on the market

### > PRODUCT SUPPORT

- Our dealer relationships and a fully integrated machine provide seamless support and the highest level of machine availability
- Mega is the most recognized and valuable brand of tank on the market
- Over 40 years of knowledge and experience with prime mover integration
- Every Mega water tank includes a full set of Operation and Service Manuals
- [www.megacorpinc.com](http://www.megacorpinc.com) provides useful information and complete contacts for support
- Phone, online and on-site support for dealers and end users with 24 hr/day parts and advice to ensure seamless machine support
- Unsurpassed product warranties and dealer support

# MAC/MAT- MEGA ARTICULATED TRUCK TANK



## GENUINE MEGA DESIGN WITH IMPROVED PERFORMANCE & COST EFFECTIVENESS

Mega manufactures a complete line of water tanks for Caterpillar® articulated prime movers. Mega offers these products for dealer installation in kit form (MAC) or as a factory installation with Mega provided CAT® chassis (MAT). The MAC kit requires a dealer/customer supplied truck chassis. When purchased as a complete machine the machine is fully assembled and tested prior to shipment. Factory installation and testing are available on some models which may be shipped assembled from our factory in Albuquerque, N.M. depending on customer requirements and truck model. Purchasing your complete solution directly from Mega streamlines the ordering process and significantly reduces the complexities related to delivery timing and shipping.

Every tank includes a complete set of technical manuals detailing installation, operation, maintenance, inspection and replacement parts. Mega tanks are constructed with premium materials and are inspected throughout the manufacturing process to produce the best water tanks and spray systems available.

Mega stocks a complete line of service and repair parts, orders can be placed on-line through our website or by phone. Our Mega Product Support team is available to assist with all facets of installation on-site, by phone, or e-mail. Speak with your Mega sales representative for complete details.

### Available Mega MAC/MAT Water Tanks for CATERPILLAR® Articulated Trucks

MEGA MODEL	NOMINAL CAPACITY	PRIME MOVER	CHASSIS CONFIGURATION
MAC5	19,000 liters/5,000 gallons	CAT 725	STANDARD or LONG WHEELBASE
MAC6	23,000 liters/6,000 gallons	CAT 730	STANDARD or LONG WHEELBASE
MAC6 FB*	23,000 liters/6,000 gallons	CAT 730	STANDARD or LONG WHEELBASE
MAC7	27,000 liters/7,000 gallons	CAT 735	STANDARD WHEELBASE
MAC8	30,000 liters/8,000 gallons	CAT 735	LONG WHEELBASE
MAC8	30,000 liters/8,000 gallons	CAT 740	STANDARD WHEELBASE
MAC8	30,000 liters/8,000 gallons	CAT 740GC	STANDARD WHEELBASE
MAC9	34,000 liters/9,000 gallons	CAT 740	LONG WHEELBASE
MAC9	34,000 liters/9,000 gallons	CAT 745	STANDARD WHEELBASE
MAC10	38,000 liters/10,000 gallons	CAT 745	LONG WHEELBASE

For other tractor models and custom sizes please contact Mega or your local dealer for more information. Sizes and models subject to change.

\* FB-Flat Bottom

Our M.A.S.S. (Mega Anti Surge System) baffling provides the most stable, lowest profile, and longest-life tank on the market today. Chassis life is improved and maintenance decreased because our tanks are engineered in collaboration with Komatsu® to match their ROPS\*, braking, and chassis load ratings. Mega tanks are designed with safety, performance, and durability in mind which ensures load stability, standard machine handling, and long chassis service life.

Mega tanks feature a proprietary baffling system that minimizes the effects of surging water while maximizing tank longevity. The tank mounting system utilizes line-bored rear pin mounts and flexible clamp front mounts that require no welding, making tank installation and removal simple. For more information on our rigid -frame water tanks please visit our website @ [www.megacorpinc.com/equipment/water-articulated.asp](http://www.megacorpinc.com/equipment/water-articulated.asp)

## While Tanks May Look Similar On The Outside- It's What's Inside That Counts!

Fully welded baffling properly located ensures that your Mega tank is the strongest, most stable, longest lasting tank available today.

Multiple Tank Interior Access Ports provides multiple points of access to internal tank compartments.

Rear Spray Bar With 3 Spray Head configuration where the center head acts as the primary sprayer while the two outboard swiveling heads act as supplemental spray.

Mega M3 Water Pump open centrifugal water pump capable of up to 800 gpm flow (up to 80 psi).

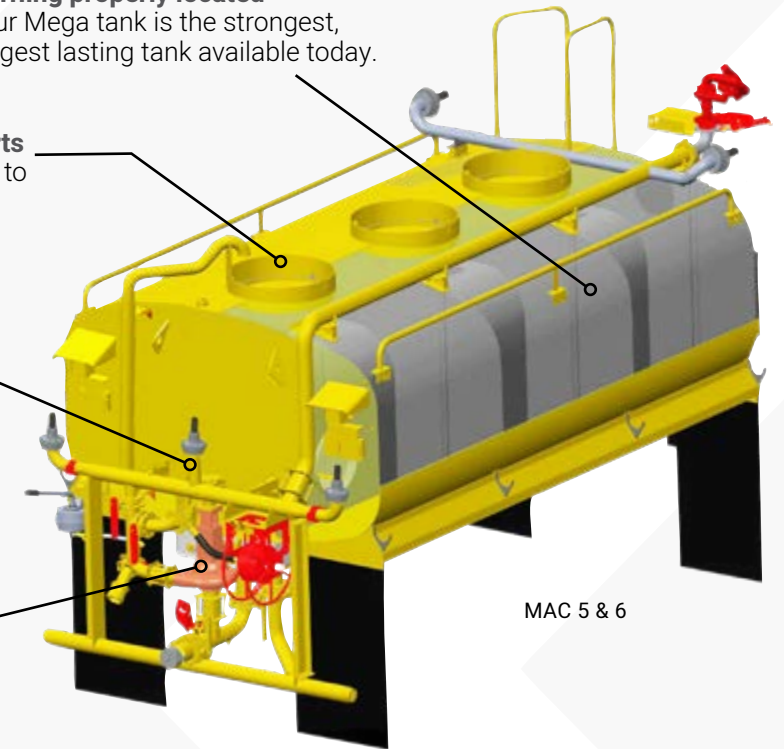

MAC 5 & 6

Single Fill Port includes a bolt-in safety grate.

Rear Spray Bar With 4 Spray Heads hydraulically actuated and adjustable.

Mega M4 Water Pump open centrifugal water pump capable of up to 1,300 gpm flow (up to 120 psi).

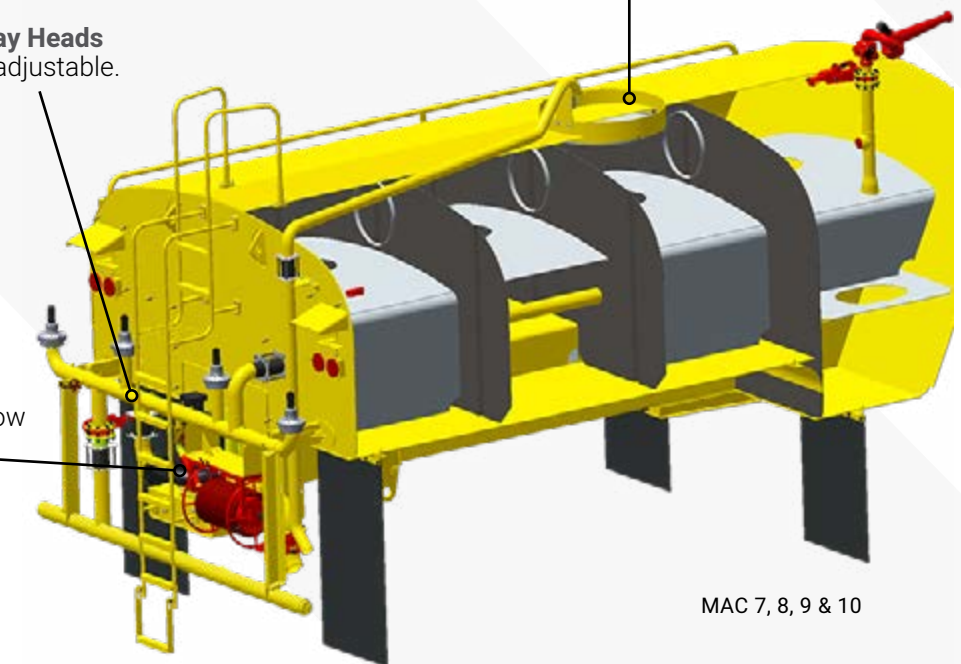

MAC 7, 8, 9 & 10

## STANDARD FEATURES

Standard features for Mega Articulated Truck Tank are subject to change and can vary by the type or model of tank. Availability of features may also vary by model. If you have any questions please contact your Mega sales representative at 505-345-2661 or toll free at 1-800-345-8889.

### QUICK REFERENCE DIRECTORY

	CAT725 MAC	CAT730 MAC	CAT735 MAC	CAT735 MAC	CAT740 MAC	CAT745 MAC	CAT745 MAC
	5	6	7	8	8	9	10
Access Ladder With Hand Rails	✓	✓	✓	✓	✓	✓	✓
Anti-Surge Baffling System (M.A.S.S.)	✓	✓	✓	✓	✓	✓	✓
Camera Relocation Mounting Provision*	✓	✓	✓	✓	✓	✓	✓
Digital Spray Control System-DiSCS®			✓	✓	✓	✓	✓
Direct Pin Mounting With Line-Bored Holes	✓	✓	✓	✓	✓	✓	✓
Electro-Hydraulic Spray Control System	✓	✓					
Exterior Paint	✓	✓	✓	✓	✓	✓	✓
External Water Lines	✓	✓					
Fill Port with Safety Gate & Anti-Skid Walkway 30 inch	✓	✓					
Fill Port with Safety Gate & Anti-Skid Walkway 36 inch			✓	✓	✓	✓	✓
Flexible Front Mounting	✓	✓	✓	✓	✓	✓	✓
Hydraulic Oil Cooler	✓	✓				✓	✓
Internal Water Lines			✓	✓	✓	✓	✓
LED Lighting and Utility Lights	✓	✓	✓	✓	✓	✓	✓
M3 Series Water Pump	✓	✓					
M4 Series High Performance Water Pump			✓	✓	✓	✓	✓
Mud Flaps	✓	✓	✓	✓	✓	✓	✓
One Year Warranty	✓	✓	✓	✓	✓	✓	✓
Rear Spray Bar With 3 Spray Heads	✓	✓					
Rear Spray Bar With 4 Spray Heads			✓	✓	✓	✓	✓
Technical Manuals	✓	✓	✓	✓	✓	✓	✓
Water Level Indicators	✓	✓	✓	✓	✓	✓	✓



## MEGA DIGITAL SPRAY CONTROL SYSTEM FLEXIBLE, SMART, RUGGED

There is a growing demand for precise application of water spray for dust suppression in surface mining, and construction applications to promote water conservation and operator safety. To address these issues Mega has designed the DiSCS® - Digital Spray Control System.

DiSCS® utilizes CAN Bus\* technology to operate the spray control system controlling the water pump, water spray, and water actuation. When combined with our GPS, DiSCS® provides a method to automatically regulate the amount of water spray applied relative to vehicle ground speed or distance traveled.



The DiSCS® compact switchpad is based on CAN Bus protocol and is water and dust resistant. The LED switchpad lights up with the many different watering patterns and controls.

- Simple and rugged construction for heavy-duty operation
- Adjustable switchpad brightness
- RAM® mount (where applicable) is fully adjustable to any operator
- In-cab water level indicating system
- Total system pause function
- Work light and auxiliary controls
- Durable switchpad legend inserts

### DiSCS® SPRAY SYSTEM FEATURES AND BENEFITS

- Distance-Based Spraying (Checkerboard)**  
 Alternating intermittent watering patterns reduces water consumption and ensures one steering tire and one drive tire remain on a dry surface.
- GPS**  
 Distance and speed-based operation modes utilize a GPS-based speed signal to automatically stop/start water flow when the vehicle stops/starts moving, while in GPS mode.
- Speed-Based Spraying (Continuous Coverage)**  
 Sequence-based intermittent spray system operation uses Pulse Width Modulation (PWM) to vary the amount of water flow while maintaining a continuous rate of water application, independent of speed.
- Time Based Spraying (Banding)**  
 Operator adjustable, full width, intermittent wet/dry pattern.
- Manual Spraying**  
 The system can be operated manually independent of GPS signal.

**DiSCS® SPRAY SYSTEM FEATURES AND BENEFITS**



**Reliability**

DiSCS® utilizes Mega water pump, hydraulic motor, Mega spray heads, and electro-hydraulic controls. There are no complex modifications to the vehicle's hydraulic systems or powertrain.



**Versatility**

DiSCS® is adaptable to most, if not all, pieces of water equipment found worldwide. DiSCS® can be easily installed in the field on machines originally equipped with a Mega spray system, or can be retrofit to many older models equipped with a competitor's spray systems.



**DiSCS® Retro-Fit Kits**

Mega DiSCS® spray control can be applied to virtually any older Mega or competitor's water distribution equipment offering these advantages:

- Standardized operator and maintenance training.
- Genuine Mega Product Support and parts (also available on-line, and documentation).
- Readily available repair and maintenance components, common to most Mega water distribution products.

**STANDARD DiSCS® SUPERBOX FEATURES**

The DiSCS® Superbox is a water-tight, sealed compartment with weather-proof rating built for rugged use in the harshest environments for mining and construction.



Photo includes optional equipment, sold separately.

- The Superbox consolidates the hydraulic system solenoid logic controls in a weather-proof, easy-to-access enclosure that securely protects critical components.
- Externally-mounted system filter assembly to protect hydraulic control valves.
- Logic control modules include individual fusing and self-diagnostics to assist in troubleshooting.
- Durable wiring harness with Deutsch® connections throughout. Harness includes additional pre-wired functions for easy plug-and-play of additional functions.

**WATER PUMP PROTECTION FEATURES FOR DiSCS®**

- ✓ **Soft Start/Stop**  
System controlled soft starts/stops to protect against operator induced sudden starts and stops that can decrease drive motor and water pump service life.
- ✓ **Low water**  
Automatic soft-stop when low water level is detected which prevents the dry running of the water pump.
- ✓ **Overheating**  
Automatic soft-stop after extended water pump operation with spray heads and water cannon valves closed (no water flowing from the pump).

**GPS SYSTEM FOR DiSCS®**

The DiSCS® Global Positioning System (GPS) works with existing DiSCS® 2.0 Mega spray system hardware which includes water pump, hydraulic motor, spray heads, and DiSCS® 2.0 electro-hydraulic controls. A self-contained GPS unit is used to determine ground speed.



**GPS-Based Sensing**

DiSCS® uses GPS data to determine ground speed, the GPS system is universal, there is no special application-specific engineering required and the system is not vulnerable to interference like radar-based systems.



**Self-Contained**

DiSCS® does not require connections to other vehicle systems to determine speed. Easily adaptable to a wide variety of machine applications.



**Automatic Water Consumption Reduction**

The DiSCS® system utilizes a pulsing strategy, to automatically limit the amount of water consumed, based on vehicle speed while maintaining road dust control coverage. Utilizing the pulsing strategy avoids the addition of complex and costly variable flow hydraulic systems and the resulting impact on machine reliability. Multiple application choices are available-continuous water layer, checker boarding and operator selectable.



**Automatic Shut-off**

In GPS mode the system automatically shuts off the flow of water as the vehicle comes to a stop to prevent puddling. Spraying automatically resumes as the machine begins to move again.



## MEGA ELECTRO-HYDRAULIC CAB CONTROL

The in-cab spray control module provides independent control of each spray head, water valve, and optional accessories. Included in the cab control module is an LED water level indicator. Our control module is built for rugged use in the harshest environments of mining and construction.

### Electro-Hydraulic Spray Control System

For the most demanding mining and construction environments we provide the Mega electro-hydraulic spray control system. The cab control module operates our Mega proprietary hydraulic solenoid spray control module that individually actuates all spray head valves and water valves. The spray control system operates independently from the water pump drive circuit. The solenoid module is housed in a weather tight steel housing. Mega fully supports these systems with spare parts and full time Product Support.



MEGA Cab Control

### Water Level Indicators

There are two electronic water level indicators, one in the cab control module inside the cab and the other on the solenoid control module mounted on the tank for easy viewing while filling.



## MEGA WATER PUMPS

The heart of the Mega spray system is the water pump. The water pump is powered by the vehicle's hydraulic system. Mega spray controls ensure proper integration with the chassis' hydraulic system and ECM.

The Mega M3 series heavy-duty water pump features a direct bolt-on hydraulic motor mount and steel splined coupling to simplify drive motor connection. Heavy-duty shaft and dual bearing design provide long life and high water output for superior spray pattern and water cannon performance.

The Mega M4 series high performance water pump also features direct bolt-on hydraulic motor mount and steel splined coupling to simplify drive motor connection. The vented frame cavity prevents damage from over-greasing and allows the use of an auto lubrication system. The M4 pumps are available in both standard cast iron as well as corrosion-resistant models with stainless steel waterways and fully stainless steel.



MEGA M3 Series



MEGA M4 Series



MEGA M4 Series Complete Stainless Steel



## MEGA SPRAY HEAD VALVES

### Mega Hydraulic Spray Heads

The Mega hydraulic spray head valve utilizes a custom-made, high quality, heavy-duty, double-acting hydraulic cylinder to open and close the valve portion of the spray head. This spray head is suitable for any heavy equipment prime mover, and requires a hydraulic spray control system.



### HAVE CORROSIVE WATER?

## WE OFFER COMPLETE STAINLESS STEEL SPRAY HEADS

Our complete stainless steel spray heads are best suited to resist corrosion and abrasion by the harsh waters often found in mining and construction environments. Stainless steel's resistance to corrosion and durability along with low maintenance make Mega stainless steel spray heads the ideal spray head for the toughest environments. *This is an optional feature.*



### Mega Spray Heads Valves are FULLY Adjustable!

Mega spray heads are adjustable and can be fine tuned to provide the optimal water distribution for a specific application. This allows for high efficiency, reduced water consumption, and prevention of roadway over watering.



**Spray Capability**

Mega spray head valves are fully adjustable for fan width, fan volume, and fan direction. When combined with swivels (see optional features) on the spray bar, fan direction can be adjusted on two axis. Mega spray heads provide a consistent flat fan spray over a very wide area. One or two spray heads are capable of suppressing dust on a road up to 27 meters (90 feet) wide.

**MAC/MAT 5 and 6**

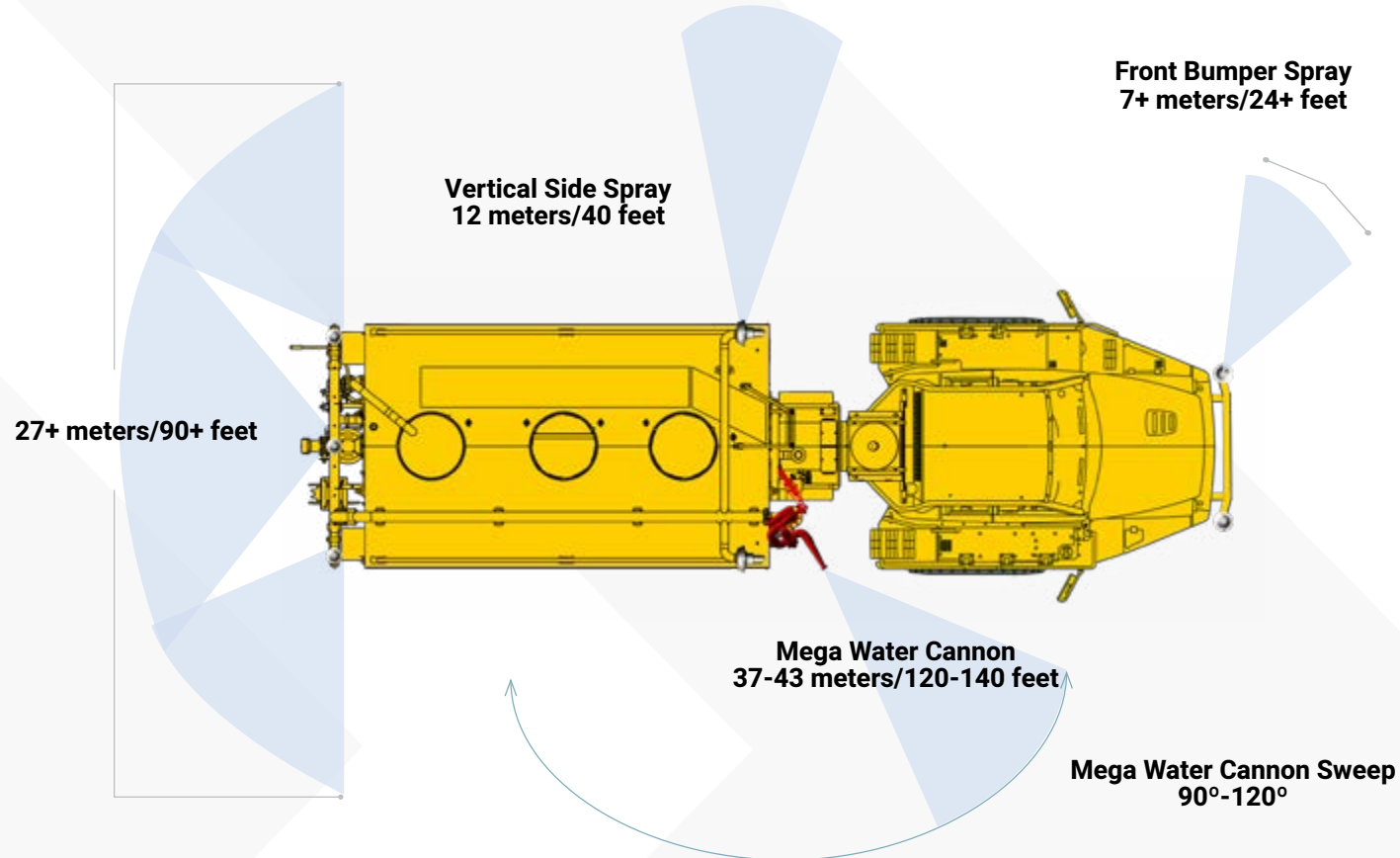

**MAC/MAT 7, 8, 9 and 10**

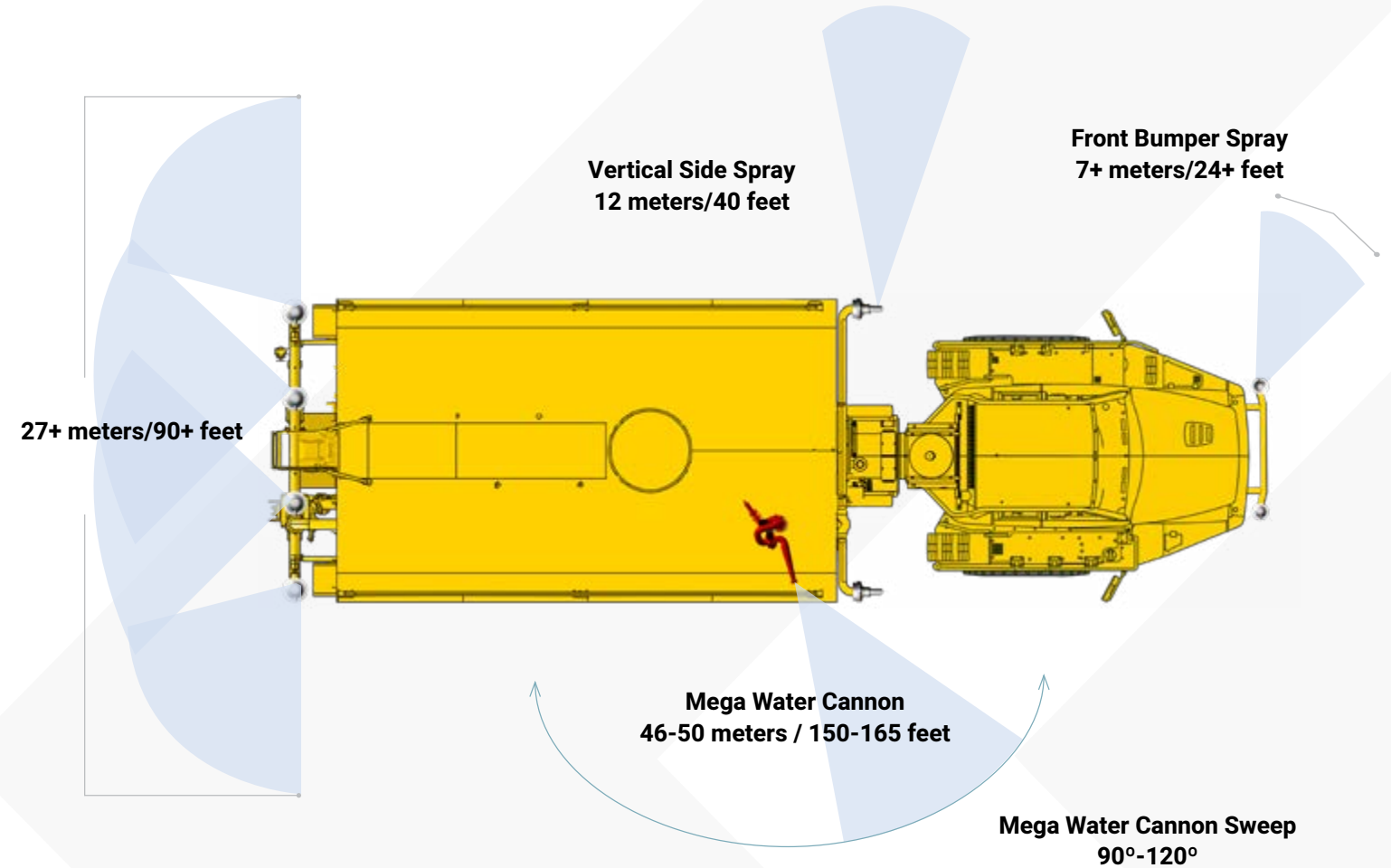

**Spray Head Configuration Flow Rates-Mega M3 Water Pump**

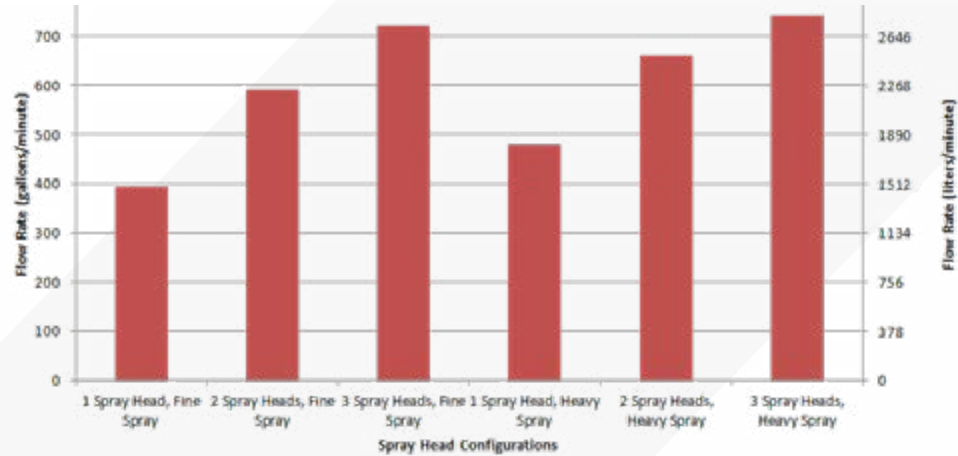

Total flow rates of different spray head configurations. The approximate total flow rates in gallons/minute (left vertical axis) and liters/minute (right vertical axis) of three possible spray head configurations. The "fine spray" opening is 1/4 inch in height, and the "heavy spray opening" setting is 3/8 inch in height.

**Spray Head Configuration Flow Rates-Mega M4B Water Pump**

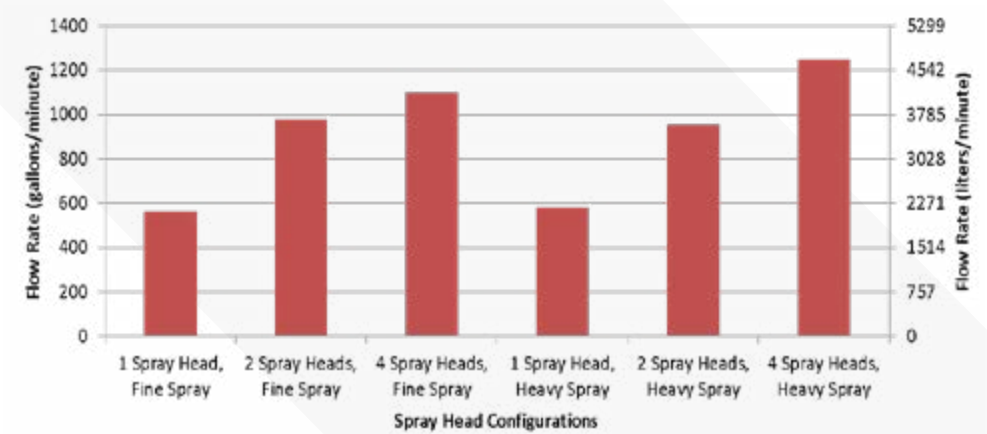

Total flow rates of different spray head configurations. The approximate total flow rates in gallons/minute (left vertical axis) and liters/minute (right vertical axis) of four possible spray head configurations. The "fine spray" opening is 1/4 inch in height, and the "heavy spray opening" setting is 3/8 inch in height.

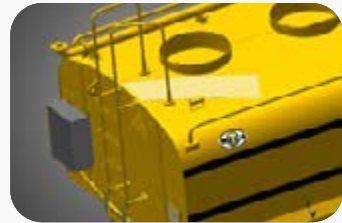

**ACCESS LADDER WITH HAND RAILS**

Mega tanks include an access ladder to the top of the tank. Our standard ladder features tread grip rungs for a sure-footed grip and hand rails at the top of the ladder allowing safe access to the top of the tank. *Optional customized safety railing is available upon request to meet your exact requirements.*

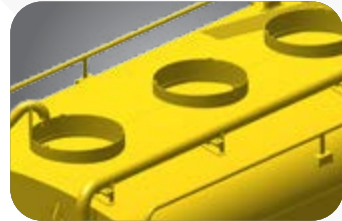

**ACCESS PORTS**

Access ports provide additional access to the interior of the tank beyond the standard access provided through the fill port. This provides multiple points of access to internal tank compartments and includes internal ladder rungs on both sides of tank. Availability varies by model.



**ACCESS MANWAYS**

Larger Mega tanks include access manways through the main transverse baffles of the tank.



**CAMERA RELOCATION MOUNTING PROVISION**

A camera mounting bracket to relocate the camera from the truck to the water tank.

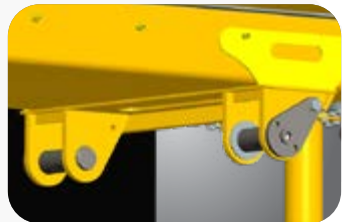

**DIRECT PIN MOUNTING WITH LINE-BORED HOLES**

Mega tanks pin directly to the rear pivot mounts of the truck chassis. Line boring the rear pivot mounts ensures accurate direct pin installation of the tank. Mega tanks do not require welding to the frame. New pivot pins and shims are supplied with the tank.

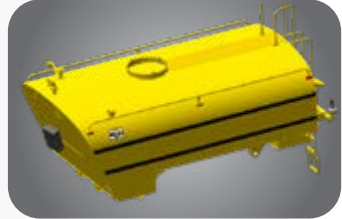

**EXTERIOR PAINT**

Mega tanks are abrasive blasted prior to application of anti-corrosive primer. The exterior top coat is color matched to the current manufacturers color. *Custom graphics are available upon request.*

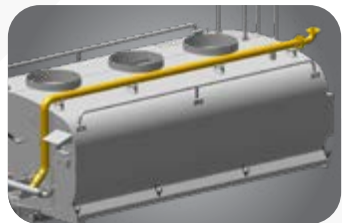

**EXTERNAL WATER LINES**

External waterways feeding front spray, vertical side spray, and water cannon are external to the tank. *Available on MAC 5 and 6 only.*



**FILL PORT WITH SAFETY GRATE AND ANTI-SKID WALKWAY**

The standard fill port includes a bolt-in safety grate. For safer access to the fill port, an anti-skid walkway is provided. The walkway extends from the access ladder on the front bulkhead to the fill port.

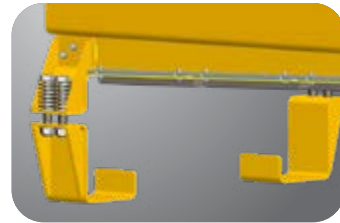

**FLEXIBLE TANK MOUNTING**

The truck chassis is allowed to flex beneath the spring type front mounting tie downs. No welding is required to install these mounts.



**HYDRAULIC OIL COOLER**

The hydraulic oil cooler helps prevent overheating during extended water pump operation.

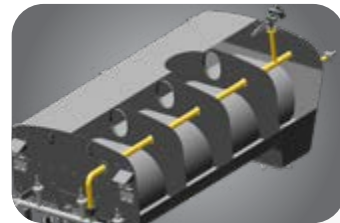

**INTERNAL WATER LINES**

Internal waterways feeding front spray, vertical side spray, and water cannon are external to the tank. *Available on MAC 7, 8, 9 and 10 only.*



**LED LIGHTING AND UTILITY LIGHTS**

All clearance, stop, and tail lights on Mega tanks are LED for long life and low maintenance. Two work lights are mounted on the rear bulkhead of the tank beneath water shedders. The lights are controlled by switches on the cab control.

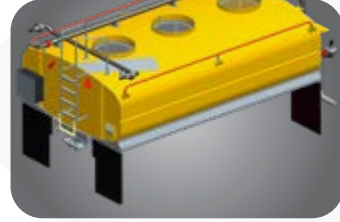

**MUD FLAPS**

Mud flaps fore and aft of rear drive tires are standard equipment on all Mega tanks.



**ONE-YEAR WARRANTY**

Mega protects your investment by providing a one-year warranty against defects in materials and workmanship. Extended warranties are available for purchase.



**REAR SPRAY BAR WITH SPRAY HEAD VALVES**

The rear spray bar is designed to fully utilize the capability of the water pump. The standard rear spray bar is constructed of carbon steel pipe. *Optional stainless steel spray bars and spray heads are available as well as swivel couplings. See our optional features.*



**TECHNICAL MANUALS**

Mega water tanks include a complete set of technical manuals detailing installation, operation, maintenance, inspection and replacement parts. Additional manuals are available for purchase.



## OPTIONAL FEATURES

Optional features for Mega Articulated Truck Tanks are subject to change and can vary by the type or model of tank. Availability of features may also vary by model. If you have any questions please contact your Mega sales representative at 505-345-2661 or toll free at 1-800-345-8889.

### QUICK REFERENCE DIRECTORY

	CAT725 MAC	CAT730 MAC	CAT735 MAC	CAT735 MAC	CAT740 MAC	CAT745 MAC	CAT745 MAC
	5	6	7	8	8	9	10
Additional Technical Manuals	✓	✓	✓	✓	✓	✓	✓
Adjustable Stream Nozzles (Fan or Fog)	✓	✓	✓	✓	✓	✓	✓
Anti-Siphon Fill Pipe	✓	✓	✓	✓	✓	✓	✓
Camera Relocation Cable	✓	✓	✓	✓	✓	✓	✓
Conical Fill			✓	✓	✓	✓	✓
Corrosion Resistant Package			✓	✓	✓	✓	✓
Digital Spray Control System-DiSCS®*	✓	✓					
Drain Valve	✓	✓	✓	✓	✓	✓	✓
Dump Bar	✓	✓	✓	✓	✓	✓	✓
Factory Installation	✓	✓	✓	✓	✓	✓	✓
Fall Protection Tie-off Points	✓	✓	✓	✓	✓	✓	✓
Foam Agent System (Requires Water Cannon)	✓	✓	✓	✓	✓	✓	✓
Front Bumper Spray (Special Request)	✓	✓	✓	✓	✓	✓	✓
Hose Reel	✓	✓	✓	✓	✓	✓	✓
Interior Coatings (Epoxy or Urethane)	✓	✓	✓	✓	✓	✓	✓
Magnesium Anodes	✓	✓	✓	✓	✓	✓	✓
On-site Assistance	✓	✓	✓	✓	✓	✓	✓
Quick Change Components Package (QCCP)	✓	✓	✓	✓	✓	✓	✓
Stainless Steel Spray Heads	✓	✓	✓	✓	✓	✓	✓
Self Loading	✓	✓	✓	✓	✓	✓	✓
Swivel Couplings on Rear Spray Bar			✓	✓	✓	✓	✓
Vertical Side Spray	✓	✓	✓	✓	✓	✓	✓
Water Cannon	✓	✓	✓	✓	✓	✓	✓

\* Please go to our standard section for DiSCS® information.



## OPTIONAL FEATURES

### FACTORY INSTALLATION

Mega offers complete factory installation for articulated truck tanks for both customer-supplied and Mega-provided tractors. Factory installation includes complete testing prior to delivery.



### ADDITIONAL TECHNICAL MANUALS

Additional sets of manuals are available for purchase. Mega water tanks include a complete set of technical manuals detailing installation, operation, maintenance, inspection and replacement parts.



### ANTI-SIPHON FILL PIPE

The anti-siphon fill pipe is used with any pressurized water source. It is specifically designed to accommodate municipal water systems and fire hydrants requiring an air gap to prevent water siphoning back into the supply.



### CAMERA RELOCATION CABLE

An extension cable to relocate your camera from the truck to the water tank.

# HOW MEGA CAN HELP YOU OPTIMIZE YOUR WATER APPLICATIONS

## MEGA WATER CANNONS



Mega's water cannons are designed and built to perform in the most severe environments of mining and construction. Capable of water pressures and flows required for the mobile water equipment industry, Mega's water cannons are ideal for fire suppression, high pressure equipment washing, and most applications that require long-distance, and/or concentrated spray.

### Specialty Nozzles

Mega's hydraulic water cannons can be fitted with a variety of adjustable nozzles to customize the spray pattern and distance. In addition to the standard straight bore nozzle, Mega offers fan to stream, fog to stream with foam education, and fog to stream nozzles. For more nozzle options please visit our website or ask your Mega sales representative for more information.

#### Adjustable Stream Nozzles (Fan or Fog)

Remote control hydraulic fan or fog stream nozzles allow adjustable stream patterns for use with Mega water cannons. *This option requires the purchase of the Mega Water Cannon.*



### Foam Agent System



The foam agent system is compatible with any class of foam that can be nozzle-aspirated. This system can be used for fires suppression or other air-aspirated foam applications. The system consists of a stainless steel (316 grade) foam concentrate tank, water cannon, and foam education nozzle. Our medium-expansion nozzles allow for adjustable foam percentages of 1%, 3%, 6%, and 10%, and possible flow rates of 350, 500, and 750 GPM.



The Mega foam tank is mounted externally on the water tank and is available in the following gallon sizes: 60, 120 and 200. Mega's foam agent system can be ordered as an option on a new Mega water tank or be purchased as a retro-kit installed to on an existing water tank.



60 gallon External Foam Tank



120 gallon External Foam Tank



200 gallon External Foam Tank



Over-watering of haul roads has been the subject of increased study by mine planning and safety personnel. Many mines have improved their efficiency, lowered resource and equipment maintenance costs, and improved the safety of their working conditions by employing water conservation practices.



#### > SAFETY

Excessive watering of roadways decreases effective tire traction, increases braking distances, destabilizes fill slopes, and accelerates erosion. This places haulage truck operators at a higher risk of accidents.



#### > WATER WASTE

Water conservation is extremely important, particularly in drier climates where water is already a scarce and precious resource. Many governments have implemented strict regulations concerning water usage, and require mines to develop and adhere to a water conservation plan.



> **LABOR AND RESOURCES** Over-watered, eroding haul roads must be serviced and repaired more frequently. When using too much water, trucks are required to return to water fill stations more often. This wastes both fuel and man-hours as well as subjecting the over-watered roads to heavier traffic.



#### > TIRE WEAR

Well-maintained haul roads will have a compacted top layer of fine-cushioning particles protecting tires from the larger coarse, sharp rocks below. Over-watering erodes this protective top layer, subjecting tires to severe wear by the exposed coarse rocks. This is costly in terms of tire replacement, lower production rates and higher labor hours.



We understand that our most precious natural resources are limited. Water conservation is essential for reducing waste and for safe road conditions, which is why we emphasize efficient water usage methods and equipment.

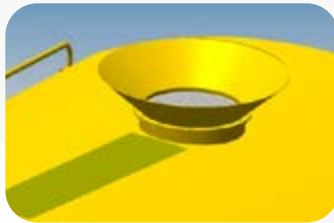

**CONICAL FILL**

The Conical Fill allows for easier positioning of the water fill source over the main fill port of the tank.

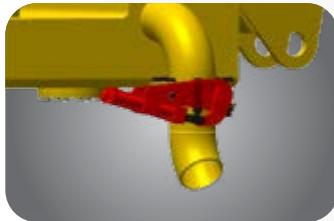

**Drain Valve**

The quick dump option is a large drain located at the bottom rear of the tank. This option is available either manually or hydraulic remote actuated for MAC6 as 101 mm/4 inch diameter and for MAC 7 and MAC8 as a 203 mm/8 inch diameter.



**DUMP BAR**

Mega offers two hydraulically-actuated dump bars. Mega's pressurized dump bar sprays penetrating jets of water directly onto the ground. The gravity dump bar is fed directly from the bottom of the water tank and may be used with the water pump turned off to reduce water flow and pressure.



**FALL PROTECTION TIE-OFF POINTS**

Multiple fall protection, D-ring style tie-off points are welded to the top of tank.



**FRONT BUMPER SPRAY KIT**

The front bumper spray is commonly used to "sweep" a surface with high pressure fans of water. Spray heads are mounted to spray from both sides of the tractor. The spray heads are fully adjustable for vertical and horizontal directions. The location of the spray bar allows the truck hood to fully tilt and open for engine service. Front bumper spray may restrict cab access. *This item is available by special request.*



**HOSE REEL**

Hose reels installed on Mega tanks include a high quality water hose and an adjustable fog to stream nozzle. Hose reels come in various sizes and are available with manual, spring, or hydraulic rewind. Sizes vary by model.



**MAGNESIUM ANODES**

Magnesium anodes are placed in each tank compartment to reduce corrosion of the tank interior.

**ON-SITE ASSISTANCE**

The Mega Product Support team offers on-site technical assistance, service advice and training to facilitate implementation and help reduce field assembly and component repair time.



**SWIVEL COUPLINGS ON REAR SPRAY BAR**

Optional swivel couplings allow for vertical spray direction adjustment. Each spray head rotates horizontally to adjust water spray fan direction.



**VERTICAL SIDE SPRAY**

Two spray head valves are mounted on the front quadrant of the tank for spraying vertical fans of water.



**QCCP-QUICK CHANGE COMPONENT PACKAGE**

Quick change component packages provide specific operation-critical parts for the Mega water tank spray system. Stocking critical parts reduces downtime by eliminating delays related to acquiring replacement parts. QCCP kits are designed specifically for each tank configuration. Contact your Mega dealer for complete parts kit list details or contact your Mega sales representative at 1-800-345-8889 for more information.



**BUY PARTS ONLINE**  
[www.megacorpinc.com](http://www.megacorpinc.com)

**PARTS AND PRODUCT SUPPORT AVAILABLE 24 HOURS A DAY, SEVEN DAYS A WEEK.**  
 Product Support 505.345.2661 • U.S. 1.800.345.8889 • After Hours & Weekend 505.345.6988

## SELF-LOADING CAPABILITY

### MAC/MAT 5 and 6

Mega MAC/MAT water tanks feature optional self-loading ability via the discharge pump. Unique to Mega is the built in priming reservoir inside the water tank that floods the suction line with water when the valving is switched to load the tank. An auxiliary manual priming pump is also included. *Optional suction hoses can be ordered separately.*

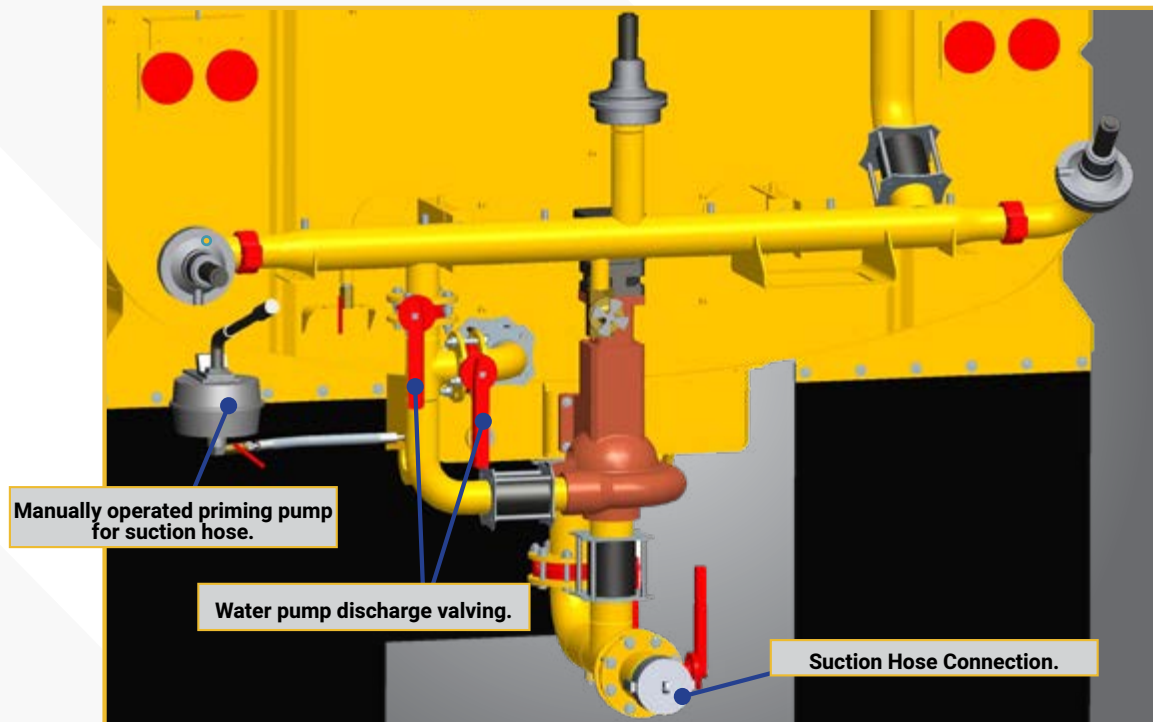

### MAC/MAT 7, 8 and 9

Mega's larger MAC/MAT water tanks also feature an optional self-loading capability via a separate pump station. The additional water pump is powered hydraulically by diverting hydraulic power from the discharge water pump via a manual diversion valve. The option includes two suction hoses, foot valve, and hose storage tubes.

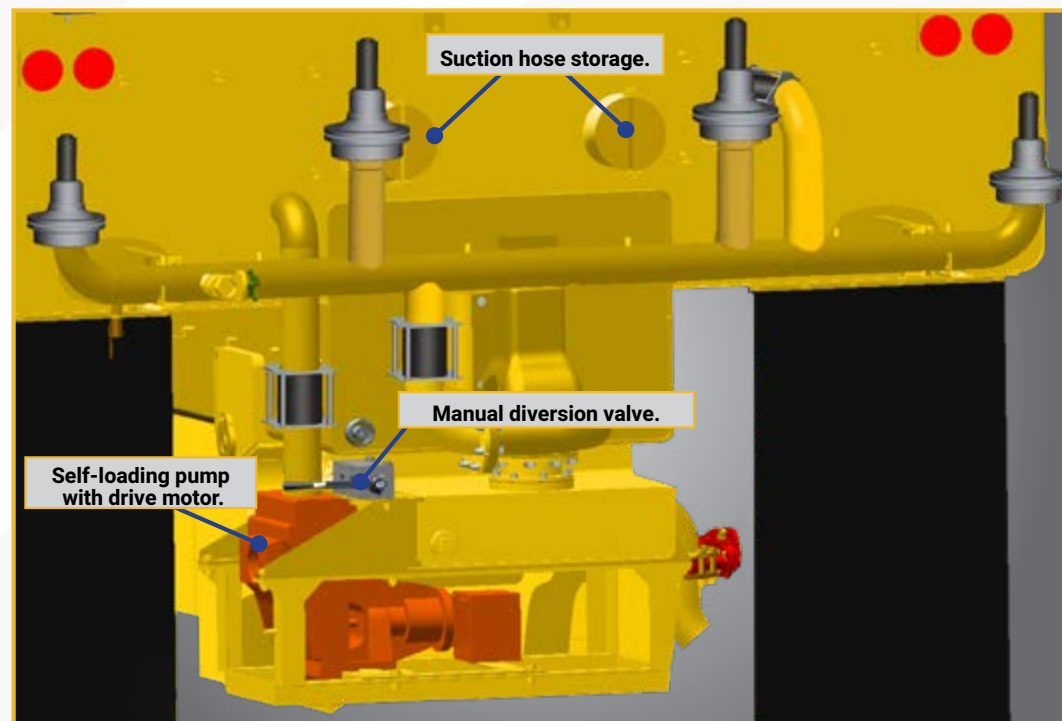

## SOLUTIONS FOR CORROSIVE ENVIRONMENTS

The Corrosion Resistant package protects against tank and component corrosion caused by the harsh waters often found in mining, construction and landfill environments. Protecting your tank against corrosion adds longevity and dependability to your tank and spray system. *Corrosion resistant package not available on MAC 5 and 6 models.*

The package consists of:

- Stainless steel spray bar
- Stainless steel spray head valves
- Corrosion resistant Mega M4 water pump with stainless steel waterways
- Stainless steel internal piping
- Stainless steel solenoid control module enclosure mounted on front bulkhead of tank



### STAINLESS STEEL SPRAY HEAD

The Mega stainless steel hydraulic spray head valve is engineered for use in the most severe environments. The stainless steel hydraulic spray head valve is interchangeable with the Mega aluminum hydraulic spray head valve. Mega hydraulic spray head valves are actuated by a stainless steel, double-acting hydraulic cylinder.



### CORROSION RESISTANT MEGA WATER PUMP

The Mega M4 series corrosion resistant water pump features a centrifugal pump manufactured with a stainless steel volute case, packing mount, and impeller. All surfaces that are in continuous contact with water utilize stainless steel construction.



### COMPLETE STAINLESS STEEL MEGA WATER PUMP

The Mega M4 series complete stainless steel water pump features a centrifugal pump manufactured with a stainless steel frame, volute case, shaft, and impeller. It is designed for maximum life in corrosive applications.



### INTERIOR COATINGS (EPOXY AND URETHANE)

Mega tanks are abrasive blasted prior to the application of the interior coating. The epoxy lining is well suited for harsh, acidic, alkaline, and salty waters. Urethane lining is very effective in normal to salty waters. *Coating data sheet and MSDS available upon request.*

## SHIPPING DIMENSIONS

All weights and dimensions are subject to change. Tank weights and specs are given without water in the tank.  
Tank specifications are available for earlier models-please contact Mega Sales for more information.

MEGA MODEL & PRIME MOVER	CHASSIS CONFIGURATION	NOMINAL CAPACITY	OVERALL LENGTH A	OVERALL HEIGHT B	OVERALL WIDTH C	TANK WEIGHT
MAC5 CAT725	SWB-Standard Wheel Base	19,000 liters	10,287 mm	4039 mm	2,845 mm	22,984 kg
		5,000 gallons	405 in	159 in	112 in	50,670 lbs
MAC5 CAT725	LWB-Long Wheel Base	19,000 liters	11,871mm	3,957 mm	2,804 mm	24,630 kg
		5,000 gallons	467 in	156 in	110 in	54,300 lbs
MAC6 CAT730	SWB-Standard Wheel Base	23,000 liters	10,922 mm	4,496 mm	2,845 mm	24,925 kg
		6,000 gallons	430 in	177 in	112 in	54,950 lbs
MAC6 CAT730	LWB-Long Wheel Base	23,000 liters	11,887 mm	4,191 mm	2,845 mm	26,463 kg
		6,000 gallons	468 in	165 in	112 in	58,342 3 lbs
MAC6 CAT730 FB	SWB-Standard Wheel Base Flat Bottom	23,000 liters	10,871 mm	4,470 mm	2,946 in	27,397 kg
		6,000 gallons	428 in	176 in	116 in	60,400 lbs
MAC6 CAT730 FB	LWB-Long Wheel Base Flat Bottom	23,000 liters	10.80 mm	4,115	2,946 in	26,761 kg
		6,000 gallons	425 in	162 in	116 in	59,000 lbs
MAC7 CAT735	SWB-Standard Wheel Base	27,000 liters	11,657 mm	4,394 mm	3,353 mm	35,153 kg
		7,000 gallons	459 in	173 in	132 in	77,500 lbs
MAC8 CAT735	LWB-Long Wheel Base	30,000 liters	12,929 mm	4,140 mm	3,429 mm	37,458 kg
		8,000 gallons	509 in	163 in	135 in	82,581 lbs
MAC8 CAT740	SWB-Standard Wheel Base	30,000 liters	11,709 mm	4,674 mm	3,429 mm	37,376 kg
		8,000 gallons	461 in	184 in	135 in	82,400 lbs
MAC9 CAT745	SWB-Standard Wheel Base	34,000 liters	12,268 mm	4,757 mm	3,429 mm	38,601 kg
		9,000 gallons	483 in	187 in	135 in	85,100 lbs

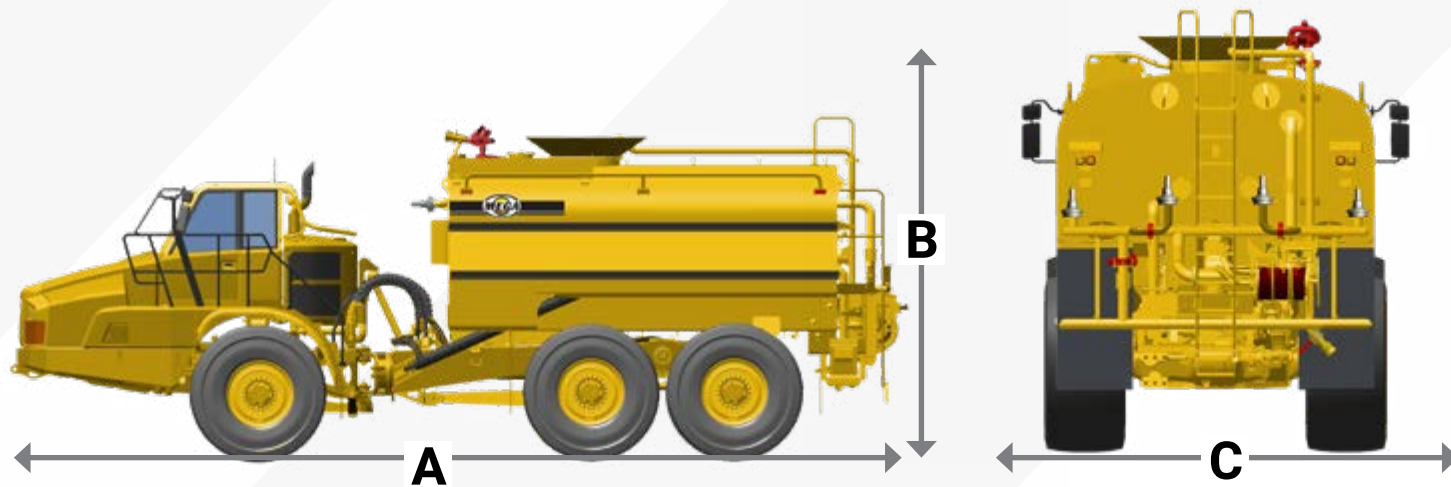

Drawings do not represent all tank models. Optional features vary.

## TANK ONLY SHIPPING DIMENSIONS

All weights and dimensions are subject to change. Tank weights and specs are given without water in the tank.  
Tank specifications are available for earlier models-please contact Mega Sales for more information.

MEGA MODEL & PRIME MOVER	CHASSIS CONFIGURATION	NOMINAL CAPACITY	OVERALL LENGTH A	OVERALL HEIGHT B	OVERALL WIDTH C	TANK WEIGHT
MAC5 CAT725	SWB-Standard Wheel Base	19,000 liters	5,613 mm	2,540 mm	2,894 mm	4,513 kg
		5,000 gallons	221 in	100 in	114 in	9,950 lbs
MAC5 CAT725	LWB-Long Wheel Base	19,000 liters	7,010 mm	1,930 mm	2,804 mm	5,579 kg
		5,000 gallons	276 in	76 in	111 in	12,300 lbs
MAC6 CAT730	SWB-Standard Wheel Base	23,000 liters	5,588 mm	2,718 mm	2,896 mm	4,831 kg
		6,000 gallons	220 in	107 in	114 in	10,650 lbs
MAC6 CAT730	LWB-Long Wheel Base	23,000 liters	7,087 mm	2,201 mm	2,896 mm	6,123 kg
		6,000 gallons	279 in	89 in	114 in	13,500 lbs
MAC6 CAT730 FB	SWB-Standard Wheel Base Flat Bottom	23,000 liters	6,934 mm	2,388 mm	2,870	6,123 kg
		6,000 gallons	273 in	94 in	113 in	13,500 lbs
MAC6 CAT730 FB	LWB-Long Wheel Base Flat Bottom	23,000 liters	6,934 mm	2,388 mm	2,870 mm	6,123 kg
		6,000 gallons	273 in	94 in	113 in	13,500 lbs
MAC7 CAT735	SWB-Standard Wheel Base	27,000 liters	6,858 mm	2,870 mm	3,353 mm	8,165 kg
		7,000 gallons	270 in	113 in	132 in	18,000 lbs
MAC8 CAT735	LWB-Long Wheel Base	30,000 liters	7,950 mm	2,413 mm	3,429 mm	8,845 kg
		8,000 gallons	313 in	95 in	135 in	19,500 lbs
MAC8 CAT740	SWB-Standard Wheel Base	30,000 liters	6,883 mm	3,124 mm	3,353 mm	8,618 kg
		8,000 gallons	271 in	123 in	132 in	19,000 lbs
MAC9 CAT745	SWB-Standard Wheel Base	34,000 liters	7,192 mm	3,209 mm	3,353 mm	10,433 kg
		9,000 gallons	283 in	126 in	132 in	23,000 lbs

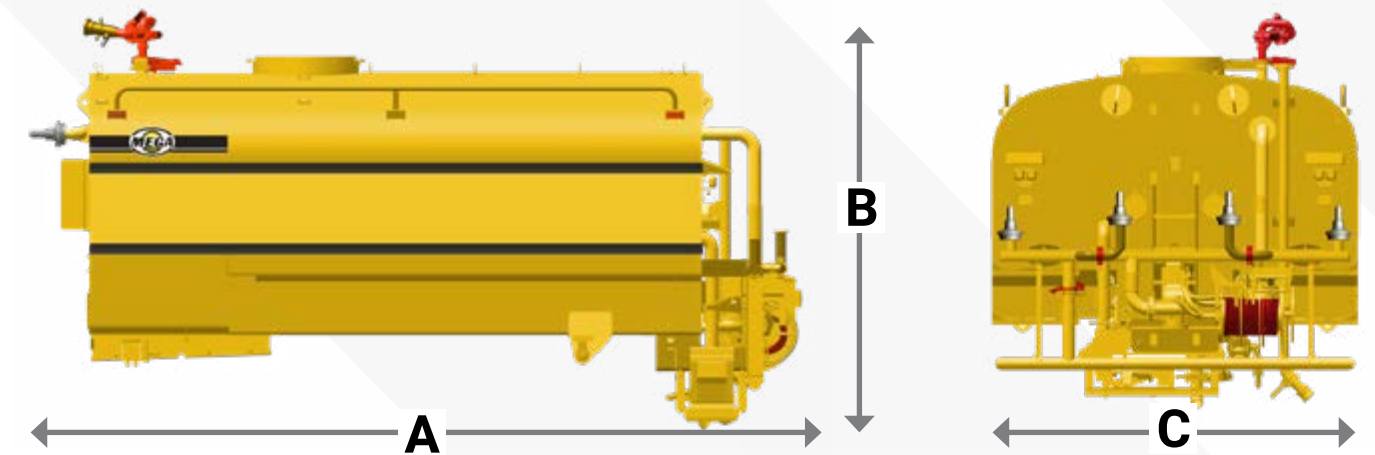

Drawings do not represent all tank models. Optional features vary.

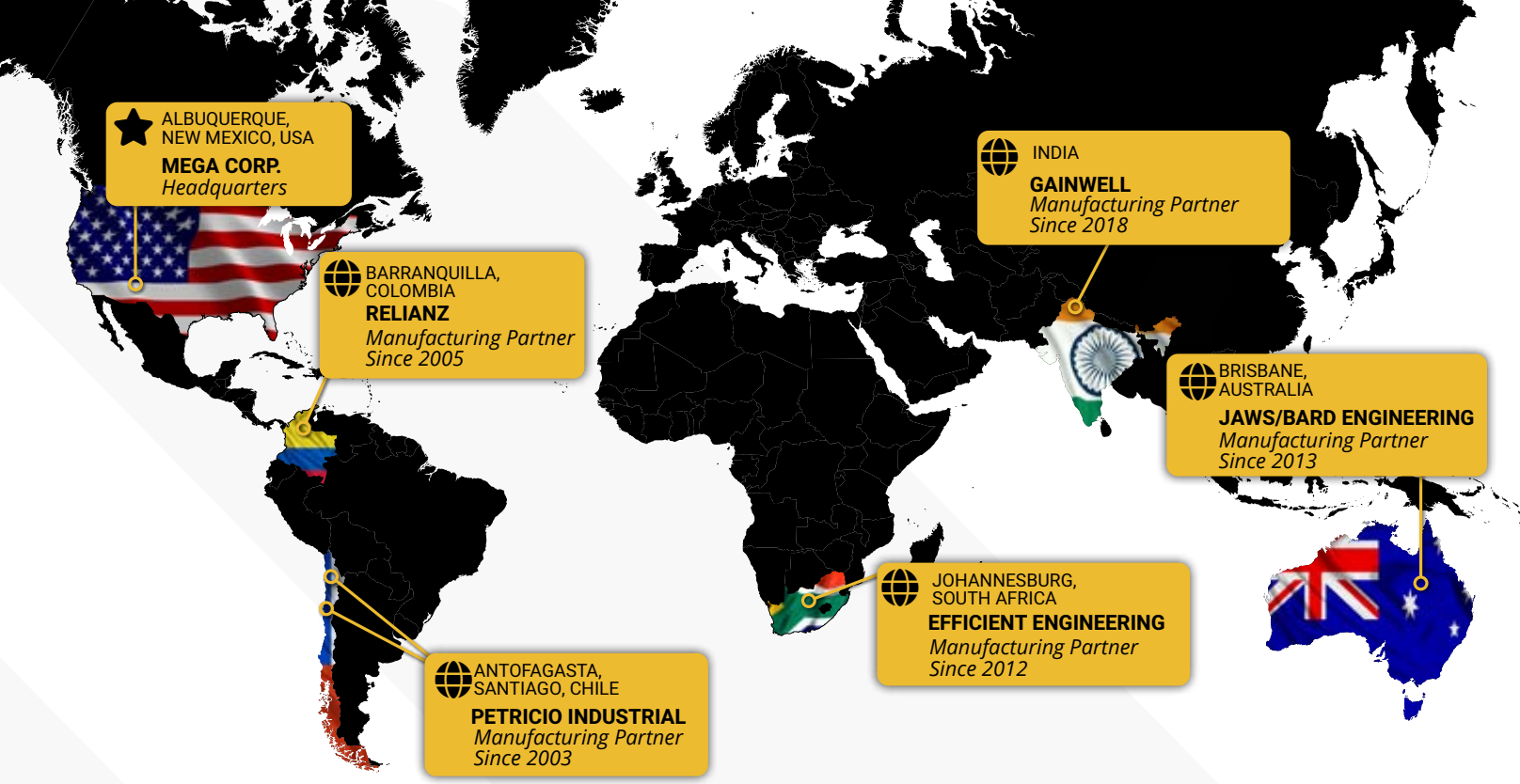

★ ALBUQUERQUE, NEW MEXICO, USA  
**MEGA CORP.**  
Headquarters

🌐 BARRANQUILLA, COLOMBIA  
**RELIANZ**  
Manufacturing Partner  
Since 2005

🌐 ANTOFAGASTA, SANTIAGO, CHILE  
**PETRICIO INDUSTRIAL**  
Manufacturing Partner  
Since 2003

🌐 JOHANNESBURG, SOUTH AFRICA  
**EFFICIENT ENGINEERING**  
Manufacturing Partner  
Since 2012

🌐 INDIA  
**GAINWELL**  
Manufacturing Partner  
Since 2018

🌐 BRISBANE, AUSTRALIA  
**JAWS/BARD ENGINEERING**  
Manufacturing Partner  
Since 2013

## We reach out **GLOBALLY** to take care of **YOU**

Wherever you are in the world, we're here to ensure you get the highest quality, most effective, and durable specialty haulage products in the industry. Mega is responsible for the design, development, manufacturing, marketing, and sale of products used in surface mining and construction projects worldwide.

Mega's products include all varieties of water haulage equipment, elevating scrapers, coal haulers, bottom-dump trailers, equipment transports, specialty dumper bodies, mobile pumps, stand tanks, parts, service and technical support. Mega's products are manufactured at its headquarters in Albuquerque, New Mexico, U.S.A. as well as by its partners in Chile, Colombia, India, South Africa, India and Australia.

**Parts and Product Support available 24 hours a day, Seven Days a week.**



### PRODUCT SUPPORT AFTER HOURS & WEEKEND

Saturday-Sunday  
505.341.6988 Direct



### OFFICE HOURS

Monday-Friday 7am-5pm  
505.345.2661 Office  
800.345.8889 U.S. Toll Free



### PARTS SALES AFTER HOURS & WEEKEND

Saturday-Sunday  
505.918.7271 Direct



SCAN TO VISIT OUR PRODUCT SUPPORT WEB PAGE

# Meet your **MEGA** team!

## ▶ EQUIPMENT SALES



**KEN KNOTTS**  
Regional Sales Manager  
kknotts@megacorpinc.com  
505.322.9770



**JOHN STUBBS**  
Regional Sales Manager  
jstubbs@megacorpinc.com  
505.259.5975

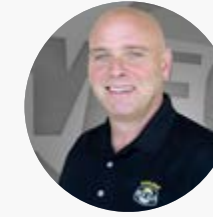

**DYLAN F. THOMAS**  
Director of Sales & Marketing  
dthomas@megacorpinc.com  
505.850.9800

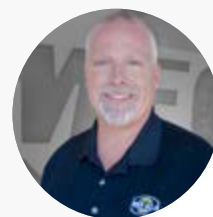

**JIM KUNZ**  
Chief Development Officer/  
Engineering Manager  
jkunz@megacorpinc.com  
505.345.2661



**CLAUDIO CÓRDOVA M.**  
Independent Sales Rep.  
Latin America  
ccordova@megacorpinc.cl  
011.56996476128



**JESSICA M. MANZANARES**  
Regional Sales Manager  
jmanzanares@megacorpinc.com  
505.341.6979



**MEAGHAN SMITH**  
Sales Support Coordinator  
msmith@megacorpinc.com  
505.341.6993



**BETZAIDA RUIZ**  
Senior Graphic Designer  
bruiz@megacorpinc.com  
505.341.6966

## ▶ PARTS SALES & PRODUCT SUPPORT

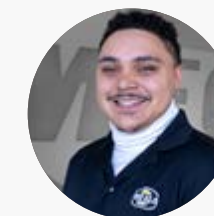

**IZAYAH BRITO**  
Parts Sales Representative  
ibrito@megacorpinc.com  
505.998.6502



**JOSE BARRAZA**  
Parts Sales Representative  
jbarraza@megacorpinc.com  
505.341.6969



**NORM REDENSHEK**  
Director Process Control,  
Product Support & Parts Sales  
nredenshek@megacorpinc.com  
505.235.4650



**BILL TAYLOR**  
Product Support  
Sales Representative  
btaylor@megacorpinc.com  
505.341.6988



**JEFF GUY**  
Product Support  
Sales Representative  
jguy@megacorpinc.com  
505.341.6989

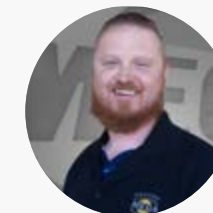

**KEVIN LEE**  
Technical Writer  
klee@megacorpinc.com  
505.341.6996

Buy parts online [www.megacorpinc.com](http://www.megacorpinc.com) or by calling Mega Parts Sales @ 1-800-345-8889.

*Thank You*  
**For Your Business**



SINCE 1976



**THERE'S WORK TO BE DONE**



**#GENUINEMEGA**

[www.megacorpinc.com](http://www.megacorpinc.com)

Follow us on social media!



MEGA CORP.®

700 Osuna Rd. N.E. • Albuquerque, NM 87113  
1.800.345.8889 • 505.345.2661 • Fax 505.345.6190  
[www.megacorpinc.com](http://www.megacorpinc.com)

01-2022 MAC/MAT CATERPILLAR Brochure  
© Mega, Inc. All Rights Reserved